

General Safety Information

⚠ WARNING

- Be careful not to let the cuffs of your clothes get caught in the chain while riding, otherwise you may fall off the bicycle.
- Check that the tension of the chain is correct and that the chain is not damaged. If the tension is too weak or the chain is damaged, the chain should be replaced. If this is not done, the chain may break and you may fall off the bicycle.
- Check that there are no cracks in the crank arms before riding the bicycle. If there are any cracks, the crank arm may break and you may fall off the bicycle.
- Obtain, read and carefully service instructions when installing parts. A loose, worn, or damaged parts may cause injury to the rider. We strongly recommend that only genuine Shimano replacement parts be used.
- Read these Technical Service Instructions carefully, and keep them in a safe place for later reference.

Note

- Check that there is no looseness in any joints or connections before riding the bicycle. (BB-FC, FC-PD)
- If you feel any looseness in the bottom bracket axle, the bottom bracket should be replaced.
- In addition, if pedaling performance does not feel normal, check this once more.
- Do not wash the bottom bracket with high-pressure jets of water.
- Apply grease to the bottom bracket before installing it.
- To ensure the best performance, be sure to use only the specified type of chain. The wide type of chain cannot be used.
- If the chain keeps coming off the sprockets during use, replace the sprockets and the chain.
- You should periodically wash the sprockets in a neutral detergent and then lubricate them again. In addition, cleaning the chain with neutral detergent and lubricating it can be an effective way of extending the useful life of the sprockets and the chain.
- Parts are not guaranteed against natural wear or deterioration resulting from normal use.
- For maximum performance we highly recommend Shimano lubricants and maintenance products.
- For any questions regarding methods of installation, adjustment, maintenance or operation, please contact a professional bicycle dealer.

Specifications

Front Chainwheel

Model number	FC-2200	FC-2203
Chainwheel teeth	52 / 39, 50 / 39T	52 / 42 / 30T
Bolt circle diameter	130 mm	130 / 74 mm
Crank arm length	165, 170, 175 mm	165, 170, 175 mm
Pedal threads	BC 9/16"x20 T.P.I.	BC 9/16"x20T.P.I.
Applicable chain	CN-HG50	CN-HG50
Applicable bottom bracket	BB-UN25	BB-UN25

Bottom Bracket

Model number	BB-UN25	BB-UN25
Type	Double	Triple
Spindle length	110 mm	113 mm
Chain line	43.5 mm	45 mm
Thread dimensions	68 mm (1.37 X 24 T.P.I.) 70 mm (M36 X 24 T.P.I.)	

Installation of the bottom bracket

Install using the special tool TL-UN74.
First install the main body, then the adapter.

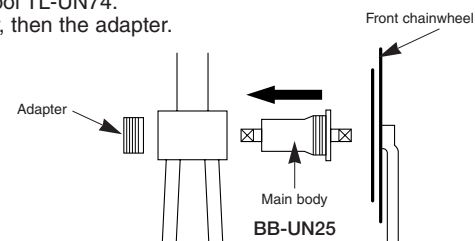

Tightening torque:
50 - 70 N·m
{435 - 608 in. lbs.}

Installation of the chain rings

Smooth shifting will not be possible if the chain rings are incorrectly installed, so be sure to install them in the correct positions.

For the FC-2200, the tooth number marking on the large chainring should face outward, and the markings on the small chainrings should face inward. Install so that the markings are in the positions shown in the illustration.

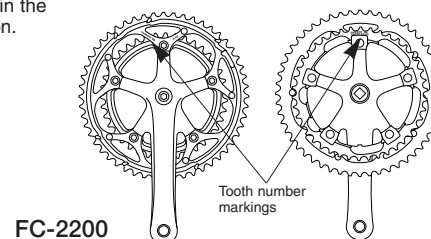

For the FC-2203, the tooth number marking on the largest chainring should face outward, and the markings on the intermediate and smallest chainrings should face inward.

FC-2203

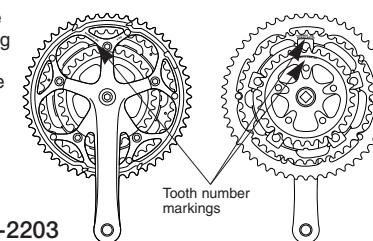

Installation of the front chainwheel

Tightening torque:
35 - 50 N·m
{305 - 435 in. lbs.}

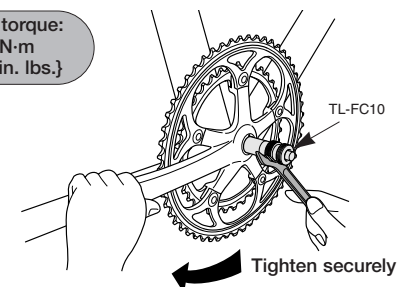

Installation of the front derailleur

1. Install and then adjust the front derailleur as shown in the illustration.

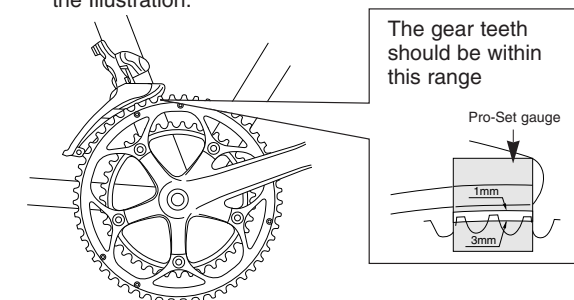

2. The level section of the chain guide outer plate should be directly above and parallel to the largest chainring.
3. Adjust the derailleur using a 5 mm Allen key.

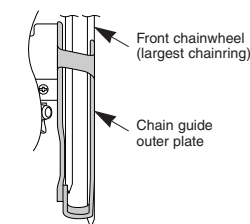

Tightening torque:
5 - 7 N·m
{44 - 60 in. lbs.}

SHIMANO®

SHIMANO AMERICAN CORPORATION
One Holland Irvine CA 92618 U.S.A. Phone 949-951-5003

SHIMANO EUROPA
Industrieweg 24 NL-8071 CT Nunspeet Holland Phone 31-341-272222

SHIMANO INC.
77 Oimatsu-cho 3-cho Sakai Osaka 590-8577 Japan

Please note: specifications are subject to change for improvement without notice. (English)
© Dec. 2002 by Shimano Inc. XBC SZK Printed in Malaysia.

Technical Service Instructions

SI-1EU0B

FC-2200
FC-2203

Front chainwheel